

Kit Contents		
Description	Part No	Pcs
Cartridge kit	BBP 32mm	1
Preload tube	BBP 32mm	2
Preload tube	BBP 32mm	2
Guide ring	BBP 32mm	2
O-ring	BBP 32mm	2
Owner's manual	Online	

**Note!**

Please note that there can be small differences between your product and the images in these instructions.

**Note!**

Please note that during storage and transport, especially at high ambient temperature, some of the oil and grease used for assembly may leak and stain the packaging. This will not cause damage to the product, wipe off the excessive oil or grease with a cloth.

**Note!**

Before you install this product, check the kit contents. If anything is missing, please contact an Big Bear Dealer.

**Warning!**

Before you install this product, read the BBP Owner's manual and watch the latest video. Give us a call if you're not sure which one to watch. This product is an important part of the vehicle and the vehicle stability.

Cartridge kit for Harley-Davidson Touring FLHx FLTx and CVO Models

**BBP 32mm**

Mounting Instructions



**⚠ Warning!**

*We strongly recommend to let a Big Bear Performance dealer install this product.*

**⚠ Warning!**

*If you work with a lifted vehicle, make sure that it is safely supported to prevent it from tipping over.*

**👁 Note!**

*When you work with this product, see the vehicle service manual for vehicle specific procedures and important data.*

**👁 Note!**

*Before you install this product clean the vehicle.*

<b>Tool</b>	<b>Part no</b>	<b>Size</b>
Pull-up tool	BBP	
Wrench (shaft nut)		19 mm
Allen key (bottom bolt)		12 mm
Tool (adjustment housing)	Large Crescent Wrench	
Tool (adjuster)		14 mm socket

## Remove the original front fork

1

Put the motorcycle on a workstand so that the front wheel barely touches the ground.

### **⚠ Warning!**

*Make sure the vehicle is securely supported so that it will not fall over.*

2

Remove the front fender, brake calipers and front wheel.

3

Release the spring preload fully (if present).

4

Note the fork leg position.

5

Loosen the upper triple clamp.

6

Loosen (do not remove) the top cap 1/2 turn.

7

Loosen the lower triple clamp.

8

Remove the front fork legs from the triple clamps.

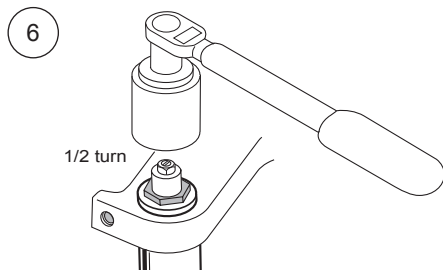
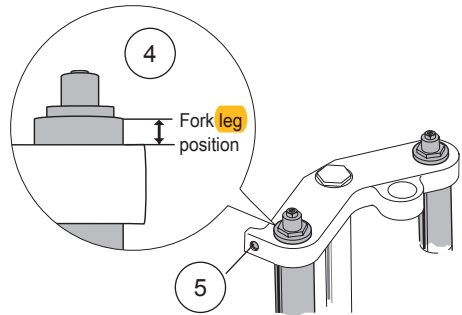
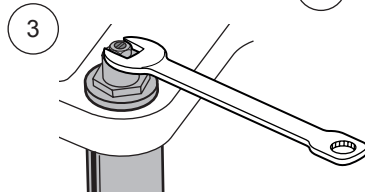

## Remove the original damping system

### **⚠ Warning!**

*Spring compression creates a potential danger because of the violent force that loaded springs are capable of.*

**Important:** *When you remove the top cap push down the top cap and at the same time pull up the inner tube to prevent uncontrolled release.*

**1**

Use an appropriate tool to loosen and remove the top cap from the inner tube. Important: When you remove the top cap push down the top cap and at the same time pull up the inner tube to prevent uncontrolled release.

**2**

Remove the preload tube, washer and the main spring.

### **👁 Note!**

*When you work with the fork leg, make sure that the inner tube (A) is at lowest position to keep the oil lock sleeve (B) correctly positioned inside the inner tube.*

**3**

Drain the fork leg from oil.

**4**

Use a 12 mm Allen key to remove the bottom bolt.

**5**

Remove the damping rod from the fork leg. Remove the top out spring and replace with top out spring provided.

### **⚠ Warning!**

*Make sure the original top out spring is removed and replaced with one provided.*

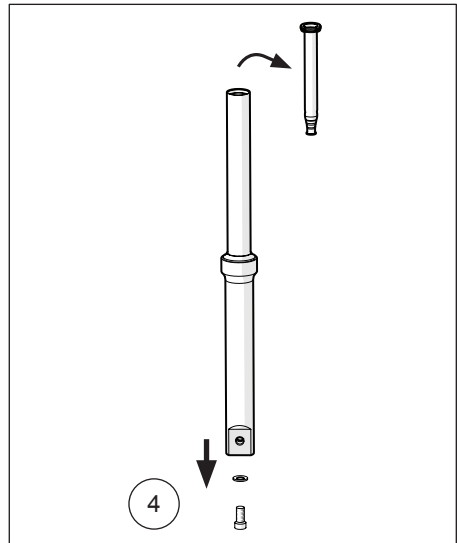
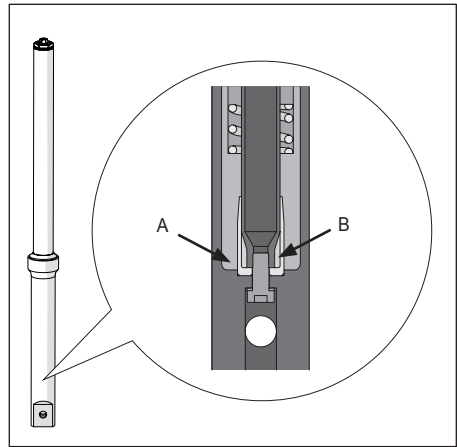
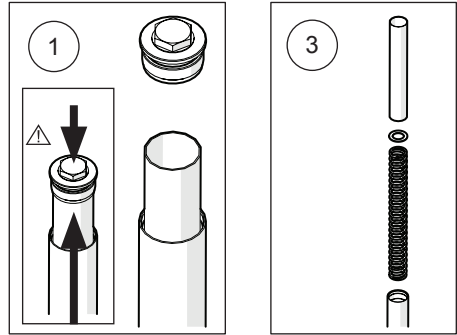

# MOUNTING INSTRUCTIONS

## Install the BBP cartridge kit

### ⚠ Caution!

Do not mix the parts. Work with only one fork leg at a time.

### ⚠ Caution!

The front fork kit consists of one compression cartridge and one rebound cartridge.

#### **Important:**

- Install the cartridge marked "Reb" (Rebound) in the right side fork leg.
- Install the cartridge marked "Comp" (Compression) in the left side fork leg.

1

Remove the top cap from the shaft.

2

Install the pull up tool on the shaft. Tighten by hand.

### ⚠ Caution!

Keep the fork leg in a vertical position during the installation procedure.

3

Make sure that the oil lock sleeve (A) and top out spring (B) is in correct position.

### ⚠ Warning!

Make sure the top out spring is in correct position.

4

Put the cartridge in the fork leg.

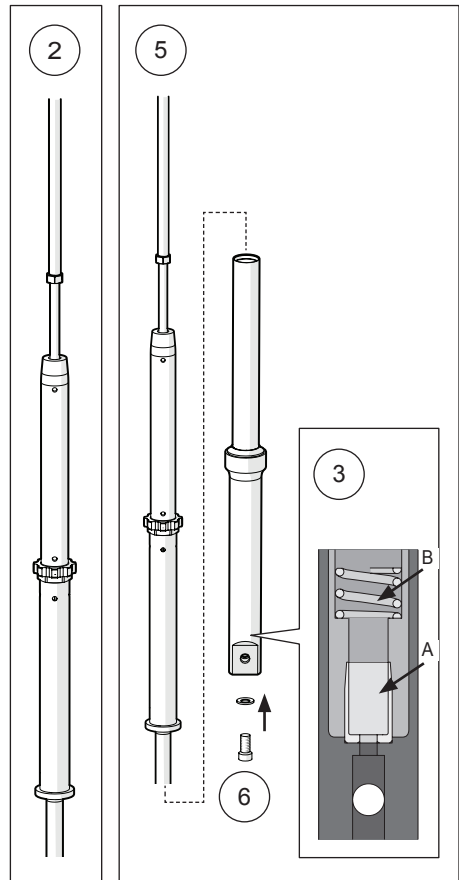

**6**

Make sure that the cartridge is in the lowest position. Refer to vehicle service manual for threadlocker and tightening torque. Install bottom bolt and washer. Use tool 12 mm allen key to tighten bottom bolt.

**7**

Pour Öhlins front fork fluid (01309-XX) in the fork leg. At BBP we only use Ohlins fork oil as our valves are set and tested with this oil. If the oil level comes near the upper end of the inner tube, move the steel tube up and down to release air trapped inside the fork leg.

**8**

Pull the inner tube up and down approximately 10 times to release all air trapped inside the fork leg.

**9**

Pull the shaft up and down approximately 10 times to release all air trapped inside the cartridge.

**10**

Make sure that the shaft, guide sleeve and inner tube is in the lowest position. Set the oil level accordingly.

**11 Note!**

Make sure to install preload spacer first after oil level is set. For stock length cartridges, there is no preload spacer. Only in 2 over.

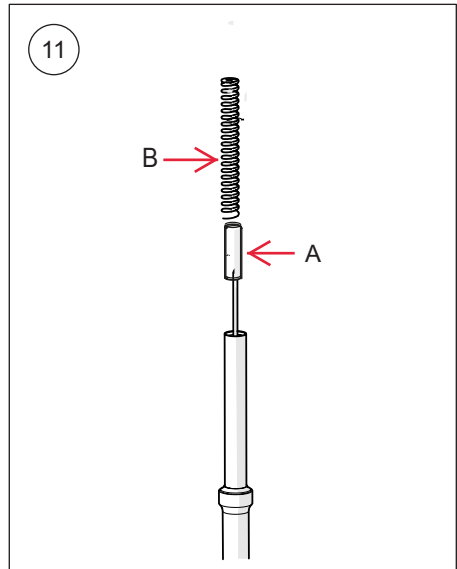
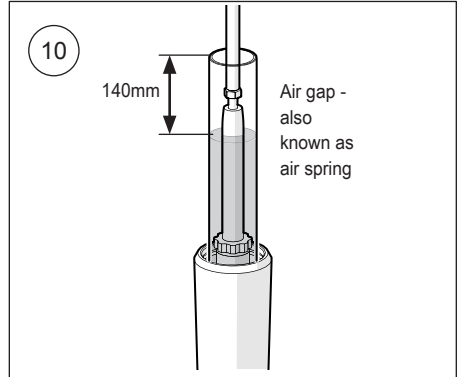

**⚠ Warning!**

*Make sure that the compression and rebound adjusters are fully open counter clockwise before installing the top cap.*

**12**

Install the top cap on the shaft until stop.

**👁 Note!**

*Make sure that the top cap is completely bottomed.*

**13**

Use a tool 14 mm socket for the preload adjuster and a 19 mm wrench to tighten the shaft nut to the top cap. Tighten the shaft nut to 12 Nm.

**14**

Pull up the inner tube and at the same time push down the top cap. Use large crescent wrench to tighten the top cap to the inner tube. Tighten the top cap to 10 Nm.

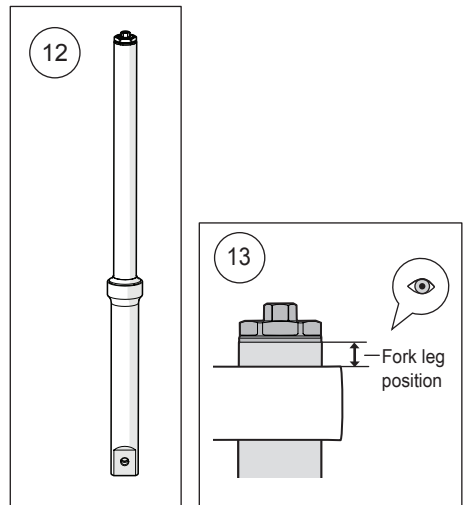

**15**

Set the compression, rebound and preload adjusters according to setup data.

**16**

Install the front fork in the vehicle at the fork leg position according to setup data. See the vehicle service manual for instructions.

**⚠ Warning!**

*Make sure to install all removed parts in the same positions as they were before the installation of the BBP cartridge kit.*

# SETUP DATA

Compression adjustment	12	clicks
Rebound adjustment	12	clicks
Öhlins Front fork fluid	01309-xx	
Oil level	140	mm
Fork leg position	Standard	